



monitoraudio.com/support



Quick start guide

# Silver Series



EN	Frequency Response	Sensitivity (2.83v @ 1m)	Nominal Impedance	Maximum SPL (Single)	Power Handling R.M.S	Recommended Amp Requirements R.M.S	Crossover Frequency	External Dimensions (inc. out-rigger plates, grille and feet + spikes where fitted) (H x W x D)	Weight
FR	Réponse en fréquence	Sensibilité (2.83v @ 1m)	Impédance nominale	SPL maximum	Puissance nominale RMS	Configuration amplificateur RMS recommandée	Fréquence de crossover	Dimensions externes (incluant les plaques de balancier, grille et pieds + pointes) (H x L x P)	Poids du produit
IT	Risposta in frequenza	Sensibilità (2.83v @ 1m)	Impedenza nominale	SPL massimo	Tenuta di potenza RMS	Requisiti consigliati amplificatore RMS	Frequenza di crossover	Dimensioni esterne (inclusi stabilizzatori, griglia e punte e piedini) (A x L x P)	Peso del prodotto
DE	Frequenzbereich	Empfindlichkeit (2.83v @ 1m)	Nennimpedanz	Max. Schalldruckpegel	Leistungsfähigkeit (RMS)	Empfohlene Verstärker-Anforderungen RMS	Übergangsfrequenz	Außenabmessungen (einschließlich Auslegerplatten, Gitter und Füße+Stifte) (H x B x T)	Produktgewicht
ES	Respuesta de frecuencia	Sensibilidad (2.83v @ 1m)	Impedancia nominal	SPL máximo	Potencia (R.M.S)	Requisitos de amplificador recomendados R.M.S	Frecuencia de separación	Dimensiones externas (con placas estabilizadoras, rejillas y pies+puntitos) (A x An x P)	Peso del producto
PT	Frequência de resposta	Sensibilidade (2.83v @ 1m)	Impedância nominal	SPL máximo	Potência de áudio (RMS)	Requisitos de amplificação recomendados (RMS)	Frequência de crossover	Dimensões externas (incluindo extensores laterais, grelha e pés + espigões) (A x L x P)	Peso do produto
NL	Frequentierespons	Gevoeligheid (2.83v @ 1m)	Nominale impedantie	Maximum SPL	Vermogen (R.M.S.)	Aanbevelen versterkervereisten (R.M.S.)	Crossoverfrequentie	Externe afmetingen (inclusief stelplaten, grille en voetjes+spijkers) (H x B x D)	Gewicht product
CN	频率响应	灵敏度 (2.83v @ 1m)	标称阻抗	最大声压级	功率容量 R.M.S	建议功放要求 R.M.S	分音频率	外部尺寸 (含外伸支架及螺纹组件+脚钉) (高x宽x长)	重量
RU	Частотный диапазон	Чувствит. (2.83v @ 1m)	Сопротивление	Макс. зв. давление	Мощность (RMS)	Рекомендованная мощность усилителя	Частота кроссовера	Габариты, включая опорную плиту, гриль и шпиль (B x Ш x Г)	Вес
JP	周波数応答	感度 (2.83v @ 1m)	公称インピーダンス	最大SPL	電力処理 (R.M.S)	推奨アンプ要件 (R.M.S)	クロスオーバー周波数	外部寸法 (アウトリガープレートと脚部+スパイクを含む) (高さ x 幅 x 奥行)	製品重量
AR	الاستجابة للتردد	الحساسية (2.83v @ 1m)	المقاومة الاعتيادية	الحد الأقصى لمستوى ضغط الصوت	طريقة التعامل مع الطاقة (جذر متوسط المربع)	متطلبات المضخم الموصى بها (جذر متوسط المربع)	تردد تقاطع الإشارة	الأبعاد الخارجية (بما في ذلك الشبكة والأطراف) (الطول x العرض x العمق)	وزن المنتج
PL	Pasmo przenoszenia	Czułość (2.83v @ 1m)	Impedancja nominalna	Maksymalne SPL	Moc ciągła R.M.S.	Zalecane parametry wzmacniacza R.M.S.	Częstotliwość zwozrotnicy	Zewnętrzne wymiary (wraz z wysięgnikami, nóżkami i kolcami) (H x W x D)	Waga produktu
Silver 50	47 Hz - 35 kHz	86dB	8 Ohms	104dB	100 W	40 - 100 W	2.6 kHz	284 x 165 x 272 mm 11 7/64 x 6 1/2 x 10 3/8"	5.6 kg 12 lb 6 oz
Silver 100	35 Hz - 35 kHz	87.5dB	8 Ohms	106dB	120 W	40 - 120 W	2.3 kHz	377 x 230 x 332 mm 14 3/4 x 9 1/8 x 13 5/64"	9.4 kg 20 lb 12 oz
Silver 200	34 Hz - 35 kHz	87.5dB	8 Ohms	108dB	150 W	60 - 150 W	2.7 kHz	930 x 254 x 329 mm 36 39/64 x 10 x 12 8/64"	13.7 kg 30 lb 3 oz
Silver 300	31 Hz - 35 kHz	87.5dB	8 Ohms	110dB	200 W	80 - 200 W	750Hz & 2.8 kHz	1045 x 274 x 389 mm 41 9/64 x 10 25/32 x 15 5/16"	19.3 kg 42 lb 9 oz
Silver 500	27 Hz - 35 kHz	90.5dB	8 Ohms	111dB	250 W	80 - 250 W	800Hz & 2.7 kHz	1095 x 319 x 389 mm 43 7/64 x 12 9/16 x 15 5/16"	22.5 kg 49 lb 9 oz
Silver C250	65 Hz - 35 kHz	88.5dB	8 Ohms	110dB	150 W	80 - 200 W	650 Hz & 3.3 kHz	206 x 481 x 272 mm 8 7/64 x 18 15/16 x 10 45/64"	10.6 kg 23 lb 6 oz

## Unboxing

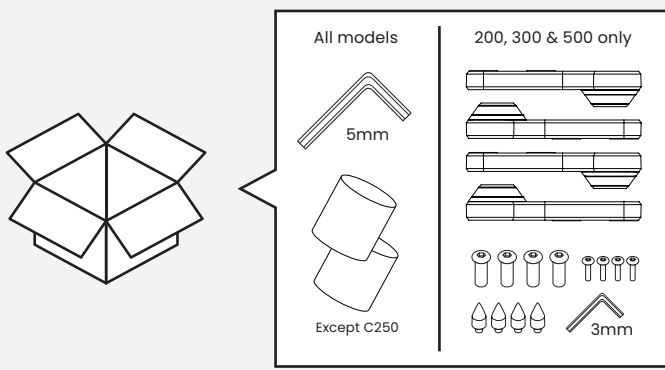

## Assembling Feet (200, 300 & 500 models only)

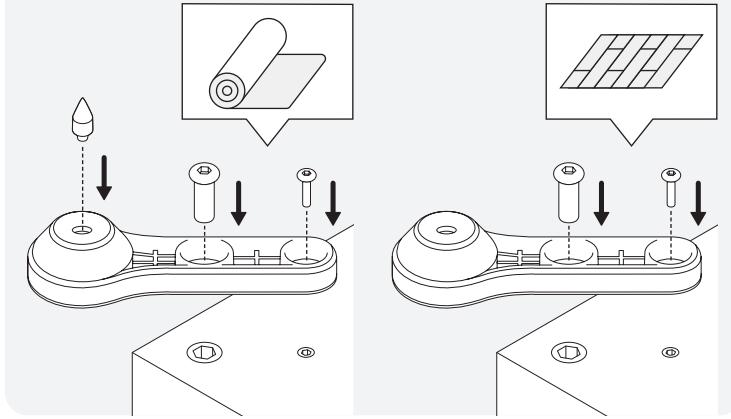

## Leveling feet

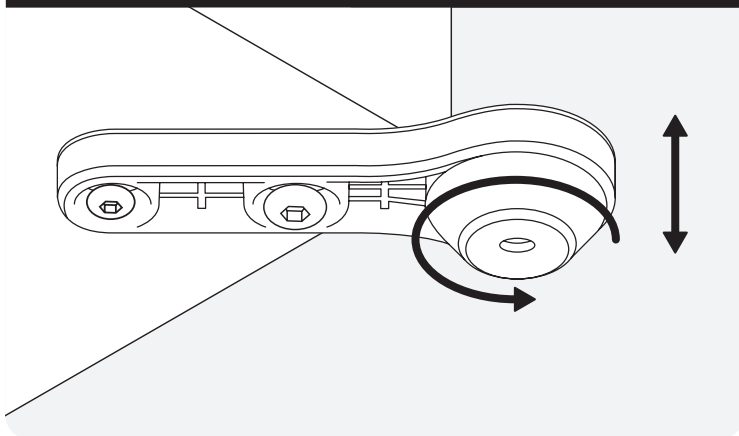

## Wiring to an amplifier

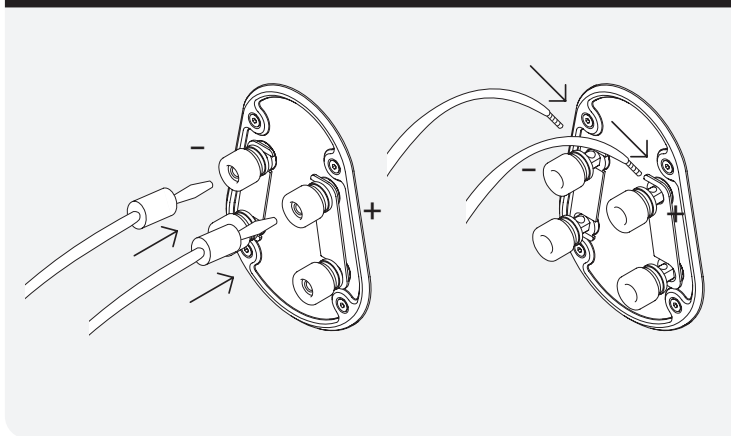

## Positioning speakers for 2 channel stereo (2.0)

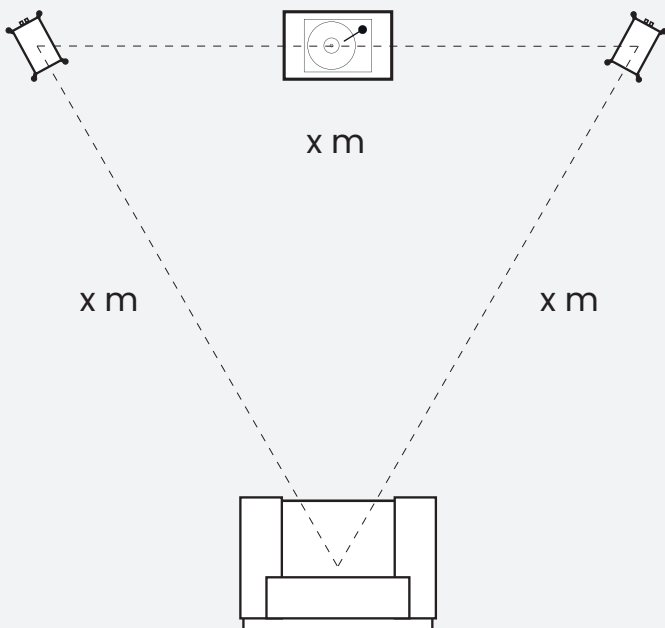

Learn more about speaker placement at [monitoraudio.com/support/faq](http://monitoraudio.com/support/faq)

## Positioning speakers for surround sound (5.1 / 7.1)

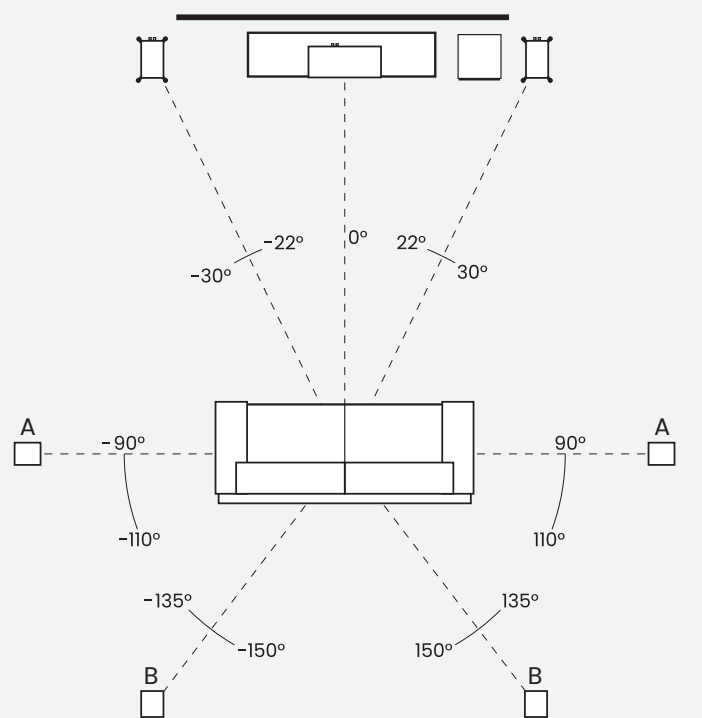

7.1 = A + B

5.1 = A